



# 2020 Making Schools Work Conference

## Exhibitor and Sponsorship Guide

Exhibit Dates: July 7-9, 2020

Conference Dates: July 7-10, 2020

**SREB** | School  
Improvement

**Making Schools Work Conference**

New Orleans, July 7-10, 2020

New Orleans Ernest N. Morial Convention Center

[sreb.org/exhibitors](https://sreb.org/exhibitors)

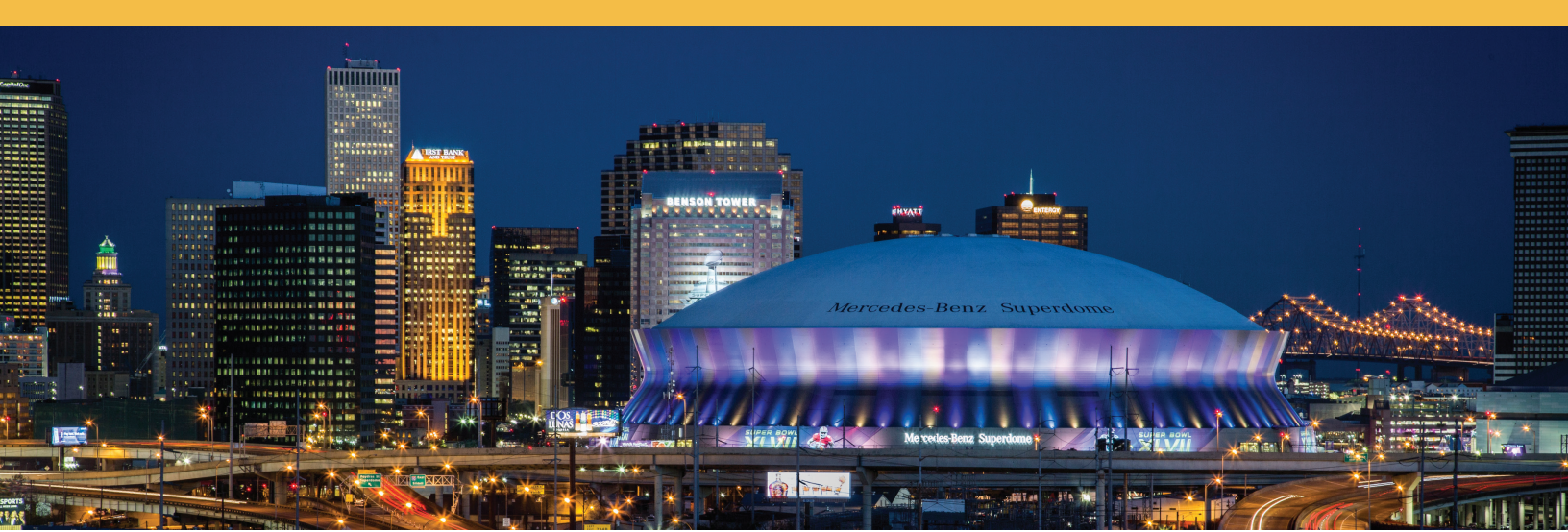

## About the Conference

**T**he Southern Regional Education Board invites you to connect with thousands of K-12 educators in New Orleans, Louisiana, July 7-10 (Education Marketplace open July 7-9) at SREB's annual Making Schools Work Conference.\*

For more than 30 years, SREB has sponsored the nation's premier professional learning event for 4,000+ teachers, counselors, principals, technology center directors and state and district education agency personnel.

The Education Marketplace in our conference Exhibit Hall is a dynamic gathering place where educators and business leaders network and explore the latest educational products and services. With numerous breaks, networking events and hands-on activities hosted in the hall, you and your business will experience great foot traffic.

\* Formerly known as the High Schools That Work Staff Development Conference.

### Why Exhibit with SREB?

- Introduce new products and services
- Generate high-quality new leads
- Connect with existing customers
- Give demonstrations
- Build brand recognition and loyalty
- Expand sales
- Learn from attendees
- Explore conference sessions

### Exhibitor Benefits

- Company name and logo on the conference website and in the program and app
- High-volume foot traffic of qualified education leaders and influencers
- Access to attendees during networking events, breaks and receptions in the exhibit hall
- Two all-access conference registrations per single booth (four for double booths)
- Company name, logo and booth number on information screens located throughout the conference venue
- Participation in the exhibit hall treasure hunt



## Exhibit Information

### The Exhibit Kit

Around April 2020, each exhibitor will receive an exhibitor kit from Shepard event services containing forms for carpeting, booth furniture, audiovisual equipment, electrical utilities, internet, drayage and shipping information. For questions about the exhibitor kit, contact Shepard at (866) 366-7428 or (404) 720-8600 or visit [shepardes.com/olk/intro.asp](http://shepardes.com/olk/intro.asp).

### Pricing

#### Single Booth

\$1,000 (\$750 nonprofit)<sup>†</sup>

#### Double Booth

\$1,800 (\$1,350 nonprofit)<sup>†</sup>

### Each Exhibit Booth Includes:

- A 10' x 10' or 20' x 10' professionally draped exhibit booth
- A 7" by 44" exhibit identification sign
- One 6' draped table, two chairs and one wastebasket (two tables and four chairs for double booths) in the exhibit hall at the New Orleans Ernest N. Morial Convention Center
- Two or four conference registrations
- Breakfast and lunch on Tuesday, Wednesday and Thursday for booth staff
- Exhibit hall security service
- Company information on conference and registration websites, the conference app and program, and venue information screens
- Participation in the exhibit hall treasure hunt<sup>‡</sup>

## Education Marketplace Hours

Mon., July 6	3 – 5 p.m. Exhibitor Move-In
Tues., July 7	7 – 10 a.m. Exhibitor Move-In
Tues., July 7	10 a.m. – 4 p.m. Exhibit Hall Open
Tues., July 7	4 – 5 p.m. Awards Reception and Prize Giveaway
Wed., July 8	8 a.m. – 4 p.m. Exhibit Hall Open
Thur., July 9	8 a.m. – 3 p.m. Exhibit Hall Open
Thur., July 9	3 – 5 p.m. Exhibitor Move-Out

## Conference Venue and Housing

The exhibit hall and all conference sessions will be hosted in the New Orleans Ernest N. Morial Convention Center. Connections Housing will act as the booking agent for all contracted hotels. To reserve a room in the conference room blocks, visit [bit.ly/MSWHousing](http://bit.ly/MSWHousing) or call (404) 842-0000 or (800) 262-9974 and mention SREB's 2020 Making Schools Work Conference. Reservations must be made by Friday, May 22, 2020, to receive the SREB room rate. Reserve your rooms early, as the SREB block tends to sell out quickly.

**To learn more and reserve your space,** visit [sreb.org/exhibitors](http://sreb.org/exhibitors) or contact [jenn.carter@sreb.org](mailto:jenn.carter@sreb.org).

<sup>†</sup> Exhibitors are responsible for additional costs not covered by the exhibit agreement, including carpeting, additional booth furniture, audiovisual equipment, electrical utilities, internet, drayage and shipping. Note that carpeting is not required by SREB or the New Orleans Ernest N. Morial Convention Center.

<sup>‡</sup> Exhibitors must sign up to participate in the treasure hunt by May 15, 2020. All attendees who complete the hunt will receive a prize item (bag, mug, notebook, shirt, etc.) and be entered to win a grand prize, such as free registrations, hotel room nights or restaurant meals at the 2021 Making Schools Work Conference at the Gaylord Opryland in Nashville, Tennessee. Exhibitors may sponsor grand prizes – contact Jenn Carter at (404) 879-5542 or [jenn.carter@sreb.org](mailto:jenn.carter@sreb.org) for details.

# Who Attends SREB's Making Schools Work Conference?

Each July, thousands of K-12 teachers, counselors, principals, technology center directors and education agency staff attend SREB's Making Schools Work Conference to participate in unparalleled professional learning experiences, hands-on workshops and networking opportunities.

Attendees choose our conferences because they know they'll take home powerful tools and strategies they can use right away to transform teaching and learning in their classrooms. Join us this year in New Orleans and collaborate with these highly engaged education professionals.

## Who attends?

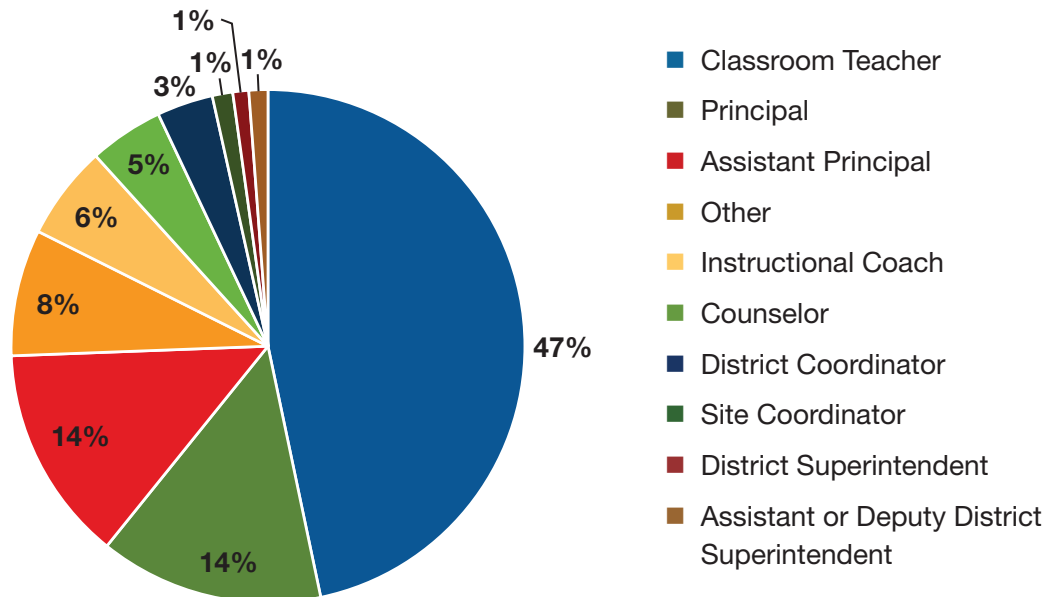

## What are their interests?

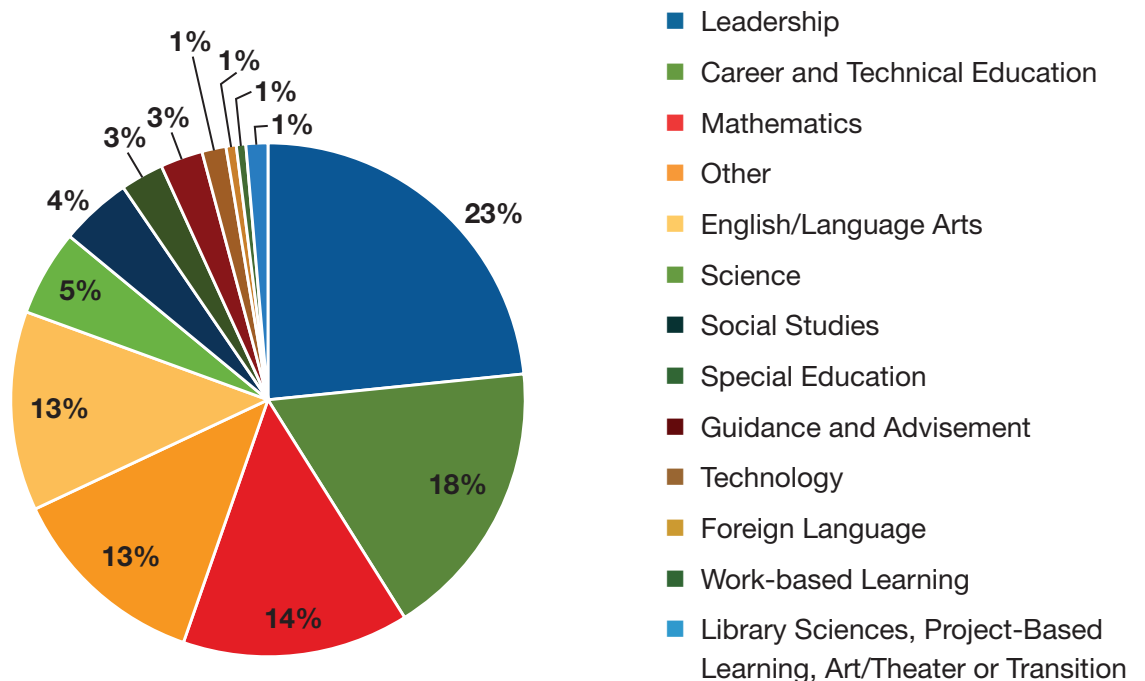

# Exhibitor Regulations and Guidelines



## Exhibitor Reservations

Make your reservations to exhibit by visiting [sreb.org/exhibitors](http://sreb.org/exhibitors). Exhibit fees are to be paid in full at the time of application submittal or prior to the conference. The exhibit fee allows only one company per booth. Multiple exhibits require a separate exhibit fee for each booth.

SREB will assign all exhibit space on a first-come, first-serve basis, but will consider the preferences of conference sponsors first and then individual exhibitors. Reservations are not transferable. SREB reserves the right to modify original space assignment as necessary. SREB reserves the right to refuse the application of any exhibitor based on lack of space, failure to submit applicable forms or deposits, a need to limit the number of similar products or services, incompatibility with the conference objectives, or any other reason at its complete discretion.

## Liability and Insurance

The exhibitor agrees to make no claim, for any reason whatsoever, against SREB, the New Orleans Ernest N. Morial Convention Center or any other contractors for loss, theft, damage or destruction of goods, or for any injury to self or employees. Nor will a claim be made for any damage of any nature or character, including damage by reason of failure to provide space for the exhibit, or for removal of the exhibit or for failure to hold the conference as scheduled. Exhibitors who wish to insure their goods must do so at their own expense.

## Unoccupied Space

Should any rented exhibitor space remain unoccupied on the opening day or should any space be forfeited due to failure to make payment, SREB reserves the right to rent that space to another exhibitor or use that space for such purposes as it may see fit without any liability on its part. This clause shall not affect the obligation of the exhibitor to pay the full amount specified in the space rental agreement should SREB not resell the space.

## Prize Drawings and Promotions

Exhibitors may not offer drawings, promotions, prizes or related activities at the conference.

## Permits and Sales Tax

Exhibitor is responsible for obtaining any and all permits and licenses necessary to sell to the public.

## Acceptability of Exhibits

SREB seeks to operate an ethical event that will inspire the confidence of all involved, attendees and exhibitors alike. SREB reserves the right to refuse to sell exhibit space to any company it deems objectionable or at cross purposes to its mission or the Making Schools Work Conference. Additionally, SREB reserves the right to require exhibitors to remove promotional materials from the show floor that are deemed objectionable. SREB also reserves the right to eject any person deemed objectionable from the event without refund.

# Exhibitor Regulations and Guidelines



## Booth Staff

Each exhibit booth may be staffed by two people for single booths or four people for double booths. Booth fees entitle these booth staff to participate in educational sessions and activities taking place in the exhibit hall, including refreshments and social activities. There is an \$80 fee for each additional person staffing the booth. This fee does not include conference access.

## No Endorsement

SREB does not approve, endorse or recommend the use of any specific commercial product or service. Exhibitors may not, therefore, imply either verbally, or in printed literature, that its products or services are approved, endorsed or recommended by SREB.

## Conflicting Meetings and Activities

Exhibitors agree not to extend invitations to meetings, receptions or other events, or otherwise encourage attendee absence from the conference facilities or the Exhibit Hall during official exhibit hours. Exhibitors must obtain approval from SREB for all activities planned during the conference. SREB reserves the right to request and enforce cessation of any non-approved activity as it sees fit.

## Fire, Safety and Health

The exhibitor agrees to accept full responsibility for compliance with local, city and state fire, safety and health ordinances regarding the installation and operation of equipment. Necessary fire precautions will be the responsibility of the exhibitor.

## Cancellations and Move-In and Move-Out Requirements

In the event written notification of intent to cancel is received by Jenn Carter by June 1, 2020, all sums paid by the exhibitor, less a fee of \$100 per booth, will be refunded. No refunds will be granted after June 1. If move-in is not conducted during scheduled times, SREB reserves the right to reassign the booth space and retain the exhibitor's booth fees. Breakdown and move-out activities must be conducted during scheduled times. **Any exhibitor who breaks down and departs before the exhibit hall closes at 3 p.m. on Thursday, July 9, may be prohibited from future exhibits.** All storage and handling charges due to failure to remove exhibit materials from the display or storage area after move-out shall be the responsibility of the exhibitor. There will be no refunds for any occurrence or acts of nature, natural or manmade, beyond the control of SREB, that limits the size of the conference audience.

## Damages to Property

Exhibitors are liable for any damage to building floors, walls, columns or tables or to any other exhibitor's property. Exhibitors may not apply paint, lacquer, adhesive or any other coating to building columns, floors, walls or tables.

## Guidelines for Display Rules and Regulations

A single booth (10' x 10') will have an 8' backwall drape and 3' side dividers. For endcaps, only the center 10' may be 8' tall. The front of a booth (5' from the aisle to the middle of a booth) may not extend any higher than 42" so as not to obscure the sight line of other exhibitors. Side rails height must not exceed 36" to prevent obstructions that would interfere with the view of other booths. High counters must be placed at least 2' back from the booth entrance so as not to cause aisle traffic.

# Join us!

To reserve your space, visit [sreb.org/exhibitors](https://sreb.org/exhibitors) or contact [jenn.carter@sreb.org](mailto:jenn.carter@sreb.org).

# Conference Sponsorship Opportunities

With a wide range of sponsorship opportunities, promotional items and special events, the Making Schools Work Conference offers great value for every marketing budget. Sponsorships are an ideal way to increase your company's visibility with educators and decision-makers at the nation's premier professional learning event for school improvement.



## Platinum Sponsor – \$10,000

- Sponsor our Celebratory Evening Reception at Mardi Gras World (Thursday, July 9)
- Recognition in all media as a Platinum Sponsor
- Electronic and print signage as a Platinum Sponsor throughout the venue and a presence in the Education Marketplace in our conference Exhibit Hall
- Eight conference registrations
- Company logo on the conference website
- Digital ad in the conference app
- Full-page ad in the conference program
- Recognition in conference eblasts to thousands of attendees



## Gold Sponsor – \$7,500

- Sponsor our opening day Pacesetter Awards Reception and Prize Giveaway (Tuesday, July 7)
- Recognition in all media as a Gold Sponsor
- Electronic and print signage as a Gold Sponsor throughout the venue and a presence in the Education Marketplace in our conference Exhibit Hall
- Six conference registrations
- Company logo on the conference website
- Digital ad in the conference app
- Full-page ad in the conference program
- Recognition in conference eblasts to thousands of attendees



## Silver Sponsor – \$5,000

- Sponsor our preconference State Networking Lunch (Tuesday, July 7)
- Recognition in all media as a Silver Sponsor
- Electronic and print signage as a Silver Sponsor throughout the venue and a presence in the Education Marketplace in our conference Exhibit Hall
- Four conference registrations
- Company logo on the conference website
- Digital ad in the conference app
- Full-page ad in the conference program
- Recognition in conference eblasts to thousands of attendees

# Conference Sponsorship Opportunities

**Opening Keynote Address Sponsor – \$5,000 (1 available).** Sponsor our Opening General Session and your company’s representative will help introduce our keynote speaker, Pedro Noguera, Distinguished Professor of Education at the Graduate School of Education and Information Studies at UCLA, on Tuesday, July 7. Your company’s name and logo will be featured on screens at the opening general session, on electronic and print signage throughout the conference for the duration of the event, on the conference website and in the app, and in conference eblasts sent to thousands of attendees. Also included are four conference registrations and a presence in the Education Marketplace.

**Wednesday General Session Sponsor – \$5,000 (1 available).** Sponsor our Wednesday General Session and your company’s representative will help introduce our speaker or panel (TBA) to a large audience in the New Orleans Theater at the New Orleans Convention Center on Wednesday, July 8. Your company’s name and logo will be featured on screens at the opening general session, on electronic and print signage throughout the conference for the duration of the event, on the conference website and in the app, and in conference eblasts sent to thousands of attendees. Also included are four conference registrations and a presence in the Education Marketplace.

**Closing Keynote Address Sponsor – \$5,000 (1 available).** Sponsor our Closing General Session and your company’s representative will help introduce our keynote speaker, Anna Nixon, co-founder of STEM4Girls, on Thursday, July 9. Your company’s name and logo will be featured on screens at the closing general session, on electronic and print signage throughout the conference for the duration of the event, on the conference website and in the app, and in conference eblasts sent to thousands of attendees. Also included are four conference registrations and a presence in the Education Marketplace.

**Conference Lanyards Sponsor – \$2,500 (1 available).** See your company’s logo worn by thousands of attendees at the Making Schools Work Conference when you sponsor SREB’s conference lanyards!

**Selfie Station Sponsor – \$1,500 (4 available).** Connect with attendees and amplify awareness of your brand with thousands of their friends! Share your company’s logo on a selfie station inside the Education Marketplace or outside the conference registration area or the New Orleans Theatre at the New Orleans Convention Center.

**Conference App Sponsor – \$500 (no limit).** Put your business in front of thousands of conference attendees. App co-sponsors will receive a full-color banner ad in our Making Schools Work Conference app – along with a full listing in the exhibitors/sponsors area of the apps. App sponsors should submit their company name, logo, address, web address, phone and email contact information, and a high-resolution JPG, GIF, EPS or PNG ad to [kirsten.sundell@sreb.org](mailto:kirsten.sundell@sreb.org). Ads must be approved for content.

**Conference Program Sponsor – \$250 (no limit).** Introduce your company’s products to attendees months before the event. Program sponsors will receive a half-page full-color ad in the 2020 Making Schools Work Conference program. Program sponsors should submit their 7.5 x 4.5” ad in a high-resolution JPG, GIF, EPS, PNG or PDF format to [kirsten.sundell@sreb.org](mailto:kirsten.sundell@sreb.org), along with their company name, address, web address, and phone and email contact information. Ads must be approved for content.

## Sponsorship Registration and Pricing

To register as a sponsor, please visit [https://s7.goeshow.com/sreb/msw/2020/become\\_an\\_exhibitor.cfm](https://s7.goeshow.com/sreb/msw/2020/become_an_exhibitor.cfm).

- |   |   |
|---|---|
| <input type="checkbox"/> \$10,000 – Platinum Sponsor  | <input checked="" type="checkbox"/> <del>\$5,000 – Closing Keynote Address Sponsor (SOLD)</del> |
| <input type="checkbox"/> \$7,500 – Gold Sponsor   | <input type="checkbox"/> \$2,500 – Conference Lanyards Sponsor                                  |
| <input type="checkbox"/> \$5,000 – Silver Sponsor   | <input type="checkbox"/> \$1,500 – Selfie Station Sponsor                                       |
| <input checked="" type="checkbox"/> <del>\$5,000 – Opening Keynote Address Sponsor (SOLD)</del> | <input type="checkbox"/> \$500 – Conference App Sponsor   |
| <input type="checkbox"/> \$5,000 – Wednesday General Session Sponsor                            | <input type="checkbox"/> \$250 – Conference Program Sponsor                                     |



# Making Schools Work Conference Maps

Education Marketplace: New Orleans Ernest N. Morial Convention Center – Halls H and I-1

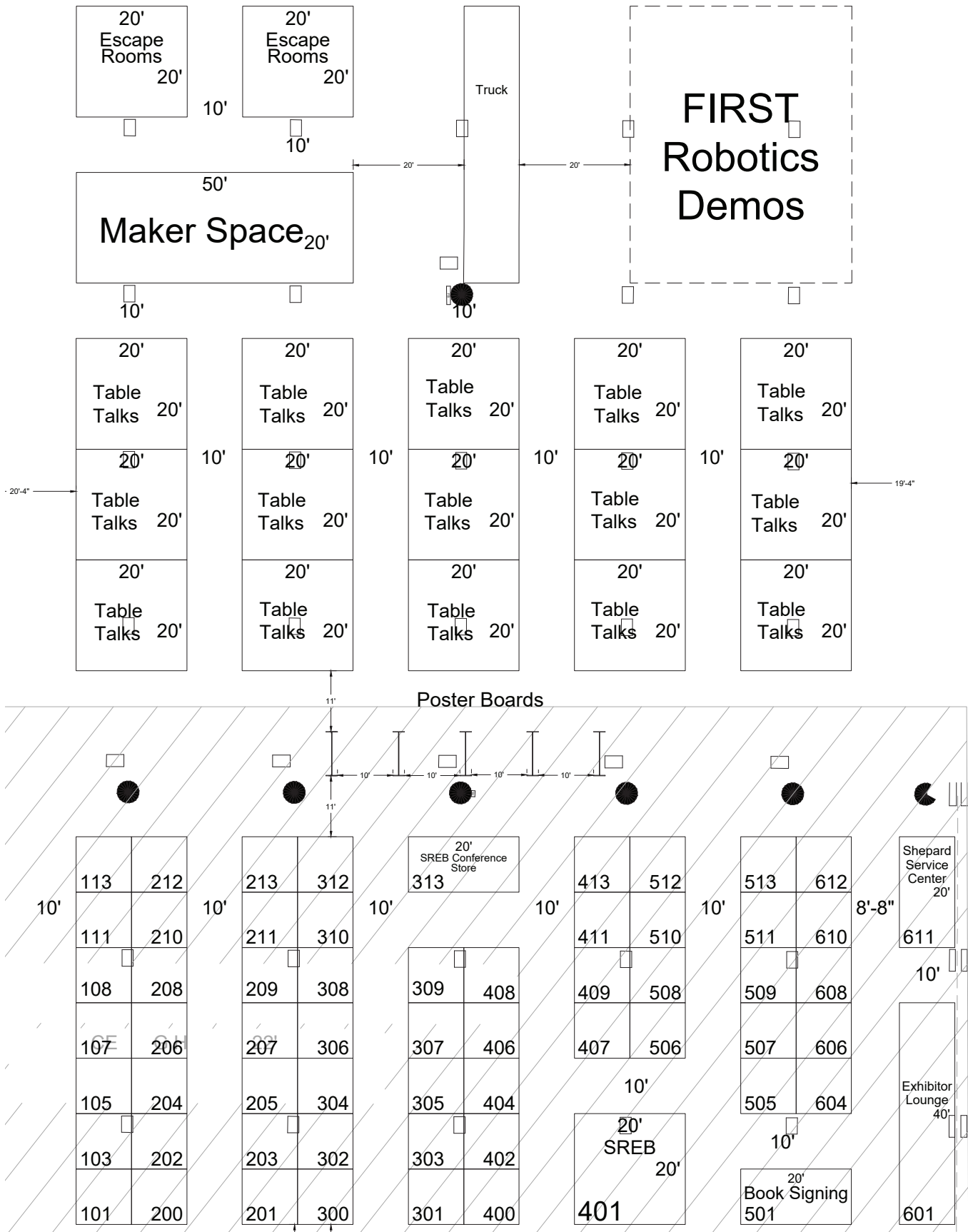

# New Orleans Ernest N. Morial Convention Center

## FIRST FLOOR



# New Orleans Ernest N. Morial Convention Center

## SECOND FLOOR

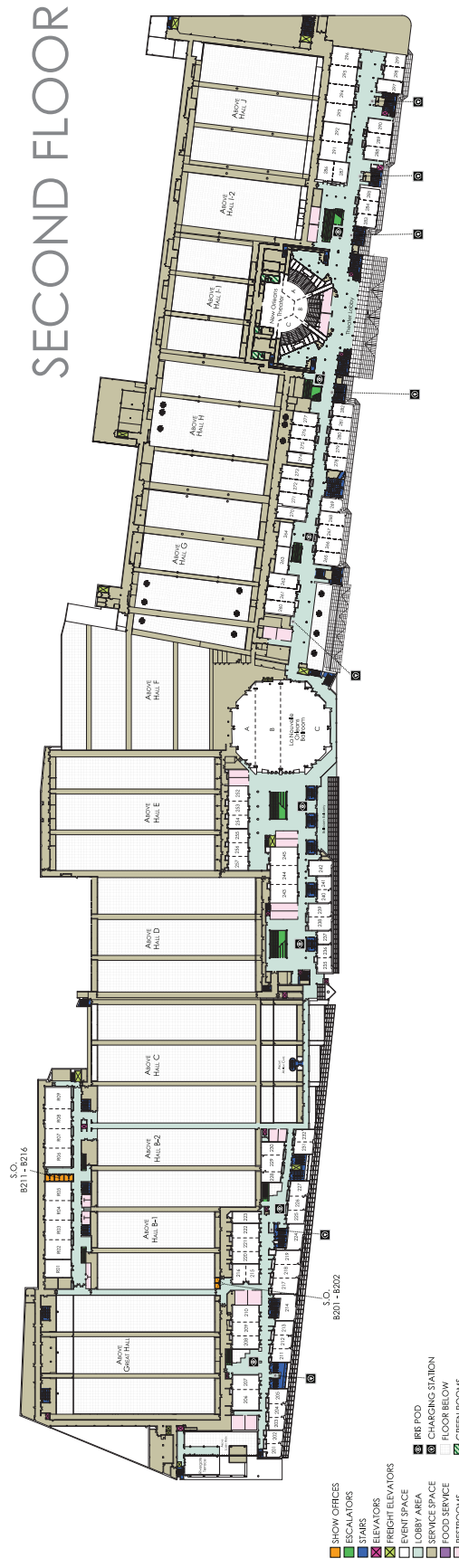

# Making Schools Work Conference Maps

THIRD FLOOR

## THIRD FLOOR ABOVE HALLS I-J



# Making Schools Work Conference Maps

## NEW ORLEANS THEATRE





**SREB** | School  
Improvement  
**Making Schools Work Conference**  
New Orleans, July 7-10, 2020

For more information on exhibiting or sponsoring,  
contact Jenn Carter at (404) 879-5542 or  
[jenn.carter@sreb.org](mailto:jenn.carter@sreb.org)

Southern Regional Education Board  
592 Tenth Street, NW  
Atlanta, GA 30318-5776  
[SREB.org/SummerConference](http://SREB.org/SummerConference)

19V19w-(R)

FEBRUARY 2020